



TECHNICAL MANUAL

CWC 600 SERIES CHILLED WATER CASSETTES



CWC (H) (T) (L) 600'S

INDEX

<u>CONTENTS</u>	<u>PAGE</u>
General.	2
Unit part numbers, dimensions & weights.	3
Kit options & features.	4
Technical data.	5/6/7
Electrical loads, airflows & discharge velocities.	7
Hydraulic resistance, sound power and sound pressure levels, coil water volume & branch duct (spigot) data.	8/9
INSTALLATION:	
Contents & dimensions.	10
Removal of chassis & mounting.	11
Pipework & valve position.	12
Electrical: Fuses, interconnecting wiring diagrams & fan speed selection.	13
Condensate piping.	14
Reinstalling chassis & fascia.	15
User maintenace.	16
Fault finding.	17
Component identification	18

GENERAL

1. TEV Ltd recommend that personnel working on this equipment be skilled and fully conversant with the appropriate Air Conditioning and Electrical practices and have sound knowledge of current Industrial Safe Working practices.
2. These units consist of CWC(T)600 chilled water cassettes and CWCH(T) with LPHW using remote wired controllers and CWC(T) 600 L chilled water cassettes CWCH(T) L with LPHW using infrared controllers.
3. These units contain live electrical components, moving parts and a supply of hot or cold water. Always site out of reach of children and protect from vandalism.
4. The data plate only gives information for the 600 unit.

PART NUMBERS

MODEL	25	45	65	75
CWC ELECTROMECHANICAL 2 PIPE	97125001	97125002	97125003	97125053
CWCT ELECTROMECHANICAL 2 PIPE	97125071	97125072	97125073	---
CWC-L INFRARED 2 PIPE	97125007	97125008	97125009	97125055
CWCTL INFRARED 2 PIPE	97125077	97125078	97125079	---
CWCH ELECTROMECHANICAL 4 PIPE	97125004	97125005	97125006	97125054
CWCHT ELECTROMECHANICAL 4 PIPE	97125074	97125075	97125076	---
CWCH-L INFRARED 4 PIPE	97125010	97125011	97125012	97125056
CWCHTL INFRARED 4 PIPE	97125080	97125081	97125082	---

--- (not available)

NOTE: Unit comes supplied with fascia packed separately under the same unit part number.

DIMENSIONS AND WEIGHTS

UNPACKED

MODEL	CWC(T)(H)600 (no fascia fitted)			
	25	45	65	75
HEIGHT mm	306	306	306	306
WIDTH mm	580	580	580	580
DEPTH mm	580	580	580	580
WEIGHT kg	21	22	23	24
CWC(T)(H)600 (with fascia fitted)				
HEIGHT mm	336	336	336	336
WIDTH mm	675	675	675	675
DEPTH mm	675	675	675	675
WEIGHT kg	23	24	25	26

PACKED

MODEL	CWC(T)(H)600 chassis				CWC(T)(H)600 fascia
	25	45	65	75	25 / 45 / 65 / 75
HEIGHT mm	360	360	360	360	100
WIDTH mm	810	810	810	810	760
DEPTH mm	610	610	610	610	760
WEIGHT kg	23	24	25	26	4

FEATURES AND OPTIONAL ACCESSORIES









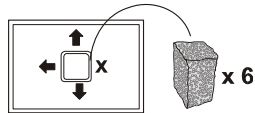
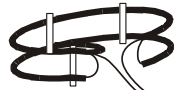

STANDARD

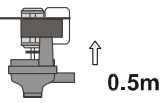
	CWC(T)	CWC-(T)L	CWCH(T)	CWCH-(T)L
Adjustable air deflection	STD	STD	STD	STD
Long life washable filter	STD	STD	STD	STD
5 fan speeds	STD	STD	STD	STD
Low Pressure Hot Water coil	---	---	STD	STD

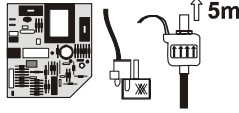
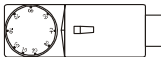
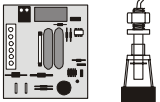
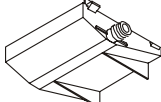
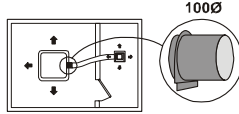
OPTIONS - (Fit any of these kits before installing the unit: some may also be factory fitted)

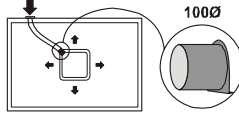
OPTIONS - (A monter avant d'installer l'unité)

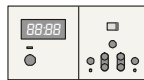
ZUBEHÖR - Alle Bausätze einbauen bevor das Gerät montiert wird)

<p>97100312 VANE MOTOR KIT KIT MOTEUR DE VOILETS LUFTLAMELLENMOTOR</p> 	<p>55500316 FOAM BLANKING KIT</p> 
<p>55200313 / 317 1 / 2 kW ELECTRIC HEATER KIT KIT BATTERIE ELECTRIQUE 1 / 2 kW 1 / 2 kW ELEKTROHEIZUNGBAUSATZ</p> 	<p>2 PORT VALVES 97125801: CWC(T)25-75 / CWCH(T)25-75 (CW) 97125803: CWCH(T)25-75 (LPHW)</p> 
<p>97100309 LIFT PUMP (0.5m) POMPE CONDENSATS (0.5m) KONDENSATPUMPE (0.5m)</p> 	<p>4 PORT VALVES 97125805: CWC(T)25 / CWCH(T)25 (CW) 97125807: CWC(T)45-75 / CWCH(T)45-75(CW) 97125811: CWCH(T)25-75 (LPHW)</p> 
<p>97100310 CONDENSATE PUMP (5m HEAD) POMPE CONDENSATS (5m) KONDENSATPUMPE (5m)</p> 	<p>96200070 PIPE THERMOSTAT</p> 
<p>97100311 HIGH LEVEL ALARM (FOR GRAVITY DRAIN)</p> 	<p>97200304 VALVE DRAIN TRAY</p> 
<p>55200306 ADJACENT ROOM SPIGOT PIQUAGE DÉRIVATION NEBENRAUMANSCHLUSS</p> 	<p>97200211 HARD WIRED WALL MOUNTED CONTROL</p> 
<p>55200305 FRESH AIR SPIGOT PIQUAGE AIR NEUF FRISCHLUFTANSCHLUSS</p> 	<p>55555309 ELECTRONIC REMOTE CONTROL (L) VERSIONS ONLY</p> 
<p>55200151 PROGRAMMABLE TIMER</p> 	<p>97200212 RETURN AIR TEMPERATURE SENSOR ELECTROMECHANICAL UNITS ONLY</p> 

NOTE: These kits are easier to fit before installation, some may also be factory fitted.

TECHNICAL DATA

COOLING CAPACITIES - 2 PIPE - kW																				Eurovent conditions shown in BOLD									
Model	Air entry dry bulb (wet bulb)		21°C (15°C)					23°C (16°C)					24°C (17°C)					27°C (19°C)											
			Fan Speed					Fan Speed					Fan Speed					Fan Speed											
	Water		1	2	3	4	5	1	2	3	4	5	1	2	3	4	5	1	2	3	4	5							
	In °C	Out °C																											
CWC25T	5	11	TC	1.19	1.30	1.37	1.46	1.60	1.36	1.53	1.67	1.93	2.27	1.49	1.70	1.86	2.13	2.49	1.94	2.30	2.58	3.01	3.54						
			SC	1.08	1.19	1.26	1.35	1.47	1.27	1.39	1.52	1.75	2.07	1.31	1.51	1.66	1.89	2.22	1.63	1.94	2.16	2.53	3.01						
	6	11	TC	1.12	1.27	1.41	1.62	1.90	1.34	1.56	1.72	1.99	2.34	1.49	1.76	1.96	2.28	2.71	2.02	2.44	2.74	3.19	3.72						
			SC	1.03	1.17	1.30	1.49	1.75	1.22	1.42	1.57	1.81	2.15	1.33	1.57	1.75	2.03	2.42	1.69	2.05	2.30	2.68	3.16						
	6	12	TC	1.04	1.14	1.20	1.32	1.48	1.25	1.45	1.55	1.71	1.91	1.37	1.55	1.69	1.95	2.34	1.77	2.08	2.31	2.69	3.20						
			SC	0.96	1.05	1.11	1.23	1.37	1.15	1.34	1.42	1.58	1.76	1.23	1.39	1.52	1.75	2.13	1.52	1.81	2.01	2.34	2.79						
7	12	TC	1.04	1.18	1.25	1.38	1.53	1.22	1.41	1.55	1.78	2.09	1.36	1.58	1.75	2.03	2.41	1.83	2.21	2.48	2.90	3.39							
		SC	0.97	1.09	1.16	1.29	1.43	1.12	1.30	1.43	1.63	1.93	1.22	1.44	1.60	1.85	2.19	1.58	1.90	2.14	2.49	2.95							
CWC45T	5	11	TC	2.22	2.51	2.60	2.96	3.33	2.58	2.95	3.05	3.56	4.16	2.91	3.34	3.51	4.18	4.95	3.79	4.55	4.82	5.94	7.16						
			SC	1.77	2.06	2.16	2.48	2.87	2.07	2.39	2.50	2.96	3.50	2.18	2.54	2.67	3.22	3.86	2.62	3.14	3.33	4.10	5.01						
	6	11	TC	2.10	2.39	2.47	2.89	3.37	2.46	2.86	3.00	3.61	4.30	2.82	3.33	3.52	4.30	5.20	3.82	4.65	4.94	6.09	7.35						
			SC	1.72	2.01	2.10	2.49	2.93	2.02	2.37	2.49	3.00	3.61	2.14	2.57	2.71	3.31	4.01	2.64	3.21	3.14	4.21	5.07						
	6	12	TC	1.97	2.23	2.32	2.63	2.93	2.33	2.66	2.76	3.17	3.67	2.64	3.00	3.13	3.68	4.33	3.47	4.11	4.35	5.33	6.47						
			SC	1.65	1.92	2.00	2.31	2.61	1.94	2.23	2.35	2.73	3.20	2.06	2.37	2.50	2.98	3.51	2.46	2.96	3.13	3.84	4.66						
7	12	TC	1.85	2.11	2.20	2.52	2.92	2.21	2.54	2.66	3.16	3.74	2.52	2.96	3.10	3.76	4.50	3.46	4.18	4.44	5.48	6.62							
		SC	1.60	1.86	1.94	2.25	2.63	1.88	2.19	2.31	2.75	3.29	1.99	2.37	2.51	3.04	3.69	2.49	3.01	3.20	3.95	4.77							
CWC65T	5	11	TC	2.60	2.93	3.18	3.54	3.99	3.02	3.42	3.71	4.14	4.70	3.40	3.85	4.19	4.66	5.42	4.26	4.85	5.38	6.22	7.52						
			SC	1.98	2.26	2.48	2.79	3.23	2.27	2.60	2.86	3.23	3.76	2.38	2.73	3.01	3.40	4.06	2.81	3.25	3.60	4.17	5.11						
	6	11	TC	2.44	2.77	3.01	3.35	3.80	2.86	3.25	3.53	3.96	4.66	3.24	3.67	4.04	4.61	5.50	4.13	4.82	5.40	6.31	7.72						
			SC	1.91	2.19	2.41	2.72	3.16	2.20	2.53	2.79	3.17	3.78	2.33	2.68	2.95	3.41	4.13	2.77	3.23	3.62	4.23	5.25						
	6	12	TC	2.32	2.61	2.84	3.14	3.54	2.73	3.09	3.36	3.74	4.21	3.10	3.50	3.80	4.23	4.83	3.95	4.47	4.93	5.64	6.80						
			SC	1.83	2.09	2.30	2.61	3.01	2.13	2.44	2.69	3.03	3.54	2.27	2.60	2.85	3.21	3.77	2.69	3.09	3.40	3.95	4.76						
7	12	TC	2.16	2.45	2.66	2.96	3.35	2.57	2.92	3.18	3.54	4.10	2.93	3.32	3.61	4.10	4.83	3.79	4.40	4.90	5.71	6.99							
		SC	1.77	2.03	2.23	2.52	2.92	2.06	2.37	2.61	2.94	3.48	2.20	2.53	2.78	3.16	3.82	2.62	3.04	3.43	3.99	4.89							

COOLING CAPACITIES - 4 PIPE - kW																							
Model	In °C	Out °C	TC	18°C db					20°C db					22°C db									
				Fan Speed					Fan Speed					Fan Speed									
				1	2	3	4	5	1	2	3	4	5	1	2	3	4	5					
CWCH25T	5	11	TC	0.95	1.08	1.21	1.37	1.64	1.20	1.38	1.52	1.74	2.10	1.30	1.58	1.76	2.04	2.48	1.69	2.02	2.25	2.60	3.12
			SC	0.87	0.99	1.11	1.26	1.50	1.09	1.26	1.38	1.59	1.91	1.15	1.40	1.57	1.81	2.20	1.46	1.74	1.94	2.24	2.69
	6	11	TC	0.99	1.15	1.26	1.45	1.74	1.18	1.40	1.55	1.79	2.16	1.31	1.57	1.74	2.02	2.42	1.74	2.08	2.31	2.65	3.10
			SC	0.91	1.06	1.16	1.33	1.60	1.08	1.28	1.43	1.65	1.99	1.18	1.41	1.57	1.81	2.18	1.50	1.79	1.98	2.28	2.70
	6	12	TC	0.89	1.00	1.08	1.22	1.44	1.06	1.21	1.32	1.50	1.80	1.22	1.40	1.54	1.78	2.14	1.56	1.87	2.08	2.40	2.87
			SC	0.81	0.93	1.01	1.13	1.34	0.98	1.12	1.22	1.38	1.65	1.10	1.28	1.40	1.62	1.95	1.36	1.62	1.81	2.09	2.52
7	12	TC	0.86	0.98	1.07	1.21	1.44	1.07	1.30	1.45	1.68	2.06	1.20	1.42	1.58	1.83	2.21	1.60	1.91	2.12	2.44	2.89	
		SC	0.80	0.91	0.99	1.13	1.34	0.99	1.19	1.33	1.55	1.90	1.09	1.29	1.44	1.67	2.01	1.40	1.68	1.86	2.14	2.55	
CWCH45T	5	11	TC	1.70	1.92	1.99	2.25	2.52	1.99	2.26	2.33	2.66	3.07	2.23	2.51	2.59	3.04	3.54	2.85	3.33	3.50	4.26	5.21
			SC	1.46	1.67	1.73	2.00	2.27	1.69	1.94	2.03	2.34	2.74	1.79	2.06	2.15	2.52	3.01	2.14	2.53	2.66	3.24	3.96
	6	11	TC	1.63	1.84	1.91	2.18	2.53	1.91	2.18	2.28	2.68	3.21	2.15	2.49	2.61	3.12	3.78	2.90	3.47	3.67	4.53	5.53
			SC	1.42	1.64	1.70	1.96	2.30	1.66	1.92	2.00	2.39	2.85	1.76	2.06	2.17	2.62	3.18	2.17	2.60	2.75	3.40	4.15
	6	12	TC	1.52	1.73	1.79	2.03	2.37	1.81	2.05	2.13	2.42	2.77	2.03	2.28	2.37	2.72	3.16	2.60	3.01	3.16	3.81	4.60
			SC	1.35	1.54	1.61	1.85	2.15	1.59	1.82	1.89	2.18	2.49	1.68	1.94	2.01	2.34	2.75	2.02	2.38	2.50	3.01	3.68
7	12	TC	1.45	1.65	1.72	1.96	2.24	1.74	1.98	2.06	2.40	2.84	1.94	2.23	2.33	2.76	3.31	2.61	3.09	3.27	4.01	4.90	
		SC	1.31	1.50	1.56	1.80	2.06	1.55	1.78	1.85	2.19	2.59	1.65	1.91	2.00	2.40	2.88	2.04	2.44	2.58	3.17	3.87	
CWCH65T	5	11	TC	2.26	2.52	2.73	3.01	3.37	2.63	2.95	3.19	3.54	4.03	2.96	3.33	3.59	4.04	4.72	3.75	4.33	4.79	5.58	6.80
			SC	1.76	2.02	2.21	2.47	2.83	2.05	2.33	2.56	2.86	3.35	2.16	2.46	2.69	3.07	3.63	2.55	2.94	3.31	3.85	4.69
	6	11	TC	2.14	2.40	2.59	2.87	3.27	2.50	2.82	3.06	3.48	4.07	2.84	3.22	3.55	4.09	4.90	3.74	4.39	4.94	5.82	7.12
			SC	1.71	1.96	2.15	2.41	2.81	2.00	2.82	2.51	2.86	3.42	2.10	2.42	2.70	3.11	3.77	2.54	2.98	3.36	3.96	4.84
	6	12	TC	2.01	2.25	2.43	2.68	3.01	2.37	2.67	2.88	2.20	3.58	2.70	3.02	3.26	3.62	4.16	3.46	3.94	4.37	5.60	6.08
			SC	1.65	1.87	2.04	2.30	2.62	1.92	2.19	2.39	2.68	3.12	2.03	2.32	2.54	2.86	3.37	2.42	2.80	3.10	3.59	4.38
7	12	TC	1.89	2.11	2.29	2.54	2.88	2.25	2.53	2.75	3.07	3.57	2.57	2.88	3.16	3.60	4.27	3.39	3.96	4.45	5.22	6.38	
		SC	1.59	1.82	1.93	2.24	2.56	1.86	2.13	2.33	2.64	3.15	1.98	2.27	2.50	2.88	3.46	2.41	2.81	3.16	3.71	4.53	

HEATING DUTIES - 4 PIPE - kW																	Eurovent conditions shown in BOLD									
Model	Air entry dry bulb		18°C db					20°C db					22°C db													
			Fan Speed					Fan Speed					Fan Speed													
	Water		1	2	3	4	5	1	2	3	4	5	1	2	3	4	5									
	In °C	Out °C																								
CWCH25T	82	71	2.13	2.43	2.73	3.03	3.33	2.03	2.33	2.53	2.93	3.23	2.00	2.23	2.43	2.73	3.13									
	70	60	1.70	1.93	2.13	2.33	2.63	1.61	1.86	2.03	2.23	2.53	1.53	1.79	1.93	2.13	2.43									
	60	50	1.30	1.51	1.64	1.83	2.03	1.22	1.42	1.55	1.73	1.93	1.15	1.33	1.45	1.63	1.73									
CWCH45T	82	71	3.78	4.38	4.58	5.38	6.08	3.58	4.18	4.38	5.18	5.88	3.53	4.08	4.28	4.98	5.68									
	70	60	3.02	3.48	3.68	4.28	4.88	2.88	3.37	3.48	4.08	4.58	2.75</													

COOLING CAPACITIES - 2 PIPE - kW																							Eurovent conditions shown in BOLD									
Model	Air entry dry bulb (wet bulb)		21°C (15°C)					23°C (16°C)					24°C (17°C)					27°C (19°C)														
	Water		Fan Speed					Fan Speed					Fan Speed					Fan Speed														
	In °C	Out °C	1	2	3	4	5	1	2	3	4	5	1	2	3	4	5	1	2	3	4	5										
CWC25	5	11	TC	1.08	1.20	1.26	1.33	1.45	1.24	1.38	1.47	1.58	1.88	1.36	1.51	1.62	1.78	2.12	1.72	1.98	2.17	2.43	3.01									
			SC	0.97	1.02	1.15	1.22	1.33	1.11	1.24	1.33	1.44	1.71	1.18	1.33	1.41	1.58	1.89	1.43	1.66	1.83	2.05	2.53									
	6	11	TC	1.02	1.13	1.21	1.31	1.58	1.20	1.36	1.48	1.64	1.99	1.33	1.52	1.67	1.86	2.28	1.76	2.07	2.29	2.58	3.18									
			SC	0.93	1.04	1.11	1.21	1.45	1.10	1.24	1.35	1.49	1.81	1.17	1.36	1.48	1.65	2.03	1.48	1.74	1.93	2.17	2.68									
	6	12	TC	0.97	1.06	1.11	1.17	1.28	1.14	1.26	1.39	1.49	1.72	1.25	1.39	1.48	1.61	1.90	1.58	1.81	1.97	2.19	2.69									
			SC	0.89	0.97	1.02	1.08	1.19	1.03	1.16	1.28	1.37	1.58	1.11	1.25	1.33	1.45	1.73	1.35	1.56	1.71	1.91	2.34									
7	12	TC	0.92	1.06	1.14	1.21	1.38	1.10	1.24	1.34	1.47	1.77	1.21	1.39	1.51	1.66	2.03	1.60	1.88	2.08	2.34	2.89										
		SC	0.85	0.99	1.06	1.12	1.29	1.01	1.14	1.23	1.36	1.63	1.09	1.25	1.36	1.51	1.84	1.38	1.62	1.79	2.02	2.49										
CWC45	5	11	TC	1.76	2.02	2.26	2.43	2.78	2.04	2.31	2.65	2.85	3.30	2.30	2.65	2.98	3.22	3.84	2.89	3.37	3.92	4.35	5.40									
			SC	1.35	1.60	1.83	1.99	2.34	1.55	1.86	2.12	2.31	2.74	1.64	1.96	2.23	2.45	2.96	1.93	2.33	2.71	3.00	3.73									
	6	11	TC	1.65	1.90	2.14	2.31	2.69	1.93	2.24	2.52	2.75	3.32	2.19	2.54	2.91	3.19	3.93	2.80	3.37	3.96	4.43	5.54									
			SC	1.30	1.56	1.78	1.94	2.29	1.51	1.81	2.07	2.28	2.76	1.60	1.90	2.21	2.46	3.02	1.91	2.32	2.73	3.06	3.83									
	6	12	TC	1.57	1.80	2.01	2.16	2.48	1.87	2.12	2.39	2.57	2.95	2.10	2.40	2.70	3.00	3.42	2.68	3.10	3.56	3.94	4.86									
			SC	1.25	1.49	1.71	1.84	2.16	1.46	1.74	1.98	2.16	2.54	1.55	1.85	2.11	2.29	2.74	1.82	2.20	2.56	2.83	3.50									
7	12	TC	1.46	1.69	1.89	2.04	2.35	1.74	2.01	2.27	2.44	2.91	1.98	2.29	2.59	2.84	3.44	2.57	3.05	3.58	3.99	4.99										
		SC	1.21	1.43	1.65	1.80	2.10	1.41	1.69	1.93	2.10	2.54	1.51	1.79	2.07	2.28	2.79	1.80	2.20	2.58	2.88	3.59										
CWC65	5	11	TC	2.17	2.47	2.78	2.97	3.42	2.51	2.85	3.23	3.47	4.00	2.82	3.21	3.63	3.89	4.50	3.52	4.02	4.56	4.94	5.93									
			SC	1.61	1.85	2.12	2.29	2.70	1.86	2.14	2.45	2.64	3.19	1.95	2.25	2.58	2.80	3.29	2.29	2.65	3.05	3.31	4.03									
	6	11	TC	2.03	2.31	2.62	2.80	3.24	2.37	2.70	3.07	3.29	3.81	2.67	3.06	3.47	3.73	4.42	3.37	3.86	4.49	4.91	6.02									
			SC	1.54	1.78	2.04	2.22	2.62	1.78	2.06	2.36	2.57	3.05	1.90	2.18	2.50	2.72	3.28	2.23	2.59	3.01	3.29	4.04									
	6	12	TC	1.94	2.20	2.47	2.64	3.05	2.27	2.58	2.92	3.12	3.62	2.58	2.94	3.32	3.56	4.09	3.27	3.74	4.24	4.54	5.41									
			SC	1.49	1.71	1.98	2.14	2.50	1.73	2.01	2.31	2.50	2.93	1.83	2.11	2.42	2.63	3.11	2.19	2.51	2.88	3.13	3.79									
7	12	TC	1.80	2.05	2.31	2.48	2.86	2.13	2.43	2.75	2.95	3.42	2.43	2.78	3.15	3.37	3.94	3.12	3.57	4.11	4.47	5.45										
		SC	1.44	1.66	1.90	2.06	2.43	1.68	1.94	2.23	2.42	2.84	1.78	2.06	2.36	2.56	3.04	2.12	2.46	2.84	3.13	3.82										
CWC75	5	11	TC	2.65	3.11	3.40	3.77	4.14	3.06	3.61	3.93	4.39	4.87	3.43	4.05	4.43	4.98	5.62	4.28	5.13	5.70	6.56	7.57									
			SC	1.94	2.33	2.55	2.90	3.23	2.24	2.67	2.95	3.34	3.75	2.37	2.84	3.10	3.54	4.04	2.78	3.33	3.71	4.33	5.00									
	6	11	TC	2.49	2.92	3.19	3.56	3.93	2.89	3.41	3.72	4.23	4.78	3.26	3.86	4.28	4.90	5.62	4.12	5.03	5.64	6.57	7.62									
			SC	1.86	2.25	2.46	2.78	3.15	2.16	2.60	2.87	3.26	3.73	2.28	2.74	3.04	3.53	4.05	2.72	3.32	3.72	4.34	5.03									
	6	12	TC	2.36	2.78	3.02	3.36	3.68	2.77	3.27	3.56	3.97	4.37	3.14	3.70	4.03	4.50	5.03	3.99	4.73	5.25	6.05	6.93									
			SC	1.82	2.16	2.38	2.69	3.01	2.11	2.52	2.77	3.13	3.50	2.23	2.67	2.94	3.33	3.78	2.63	3.17	3.52	4.05	4.71									
7	12	TC	2.20	2.58	2.82	3.15	3.46	2.60	3.07	3.35	3.75	4.22	2.97	3.50	3.86	4.38	4.99	3.81	4.62	5.17	6.01	6.97										
		SC	1.73	2.10	2.28	2.58	2.91	2.03	2.43	2.68	3.04	3.46	2.14	2.59	2.85	3.29	3.75	2.55	3.14	3.51	4.09	4.74										

COOLING CAPACITIES - 4 PIPE - kW																							Eurovent conditions shown in BOLD									
Model	Air entry dry bulb		18°C db					20°C db					22°C db																			
	Water		Fan Speed					Fan Speed					Fan Speed																			
	In °C	Out °C	1	2	3	4	5	1	2	3	4	5	1	2	3	4	5															
CWCH25	5	11	TC	0.89	0.98	1.07	1.18	1.34	1.11	1.26	1.37	1.48	1.70	1.19	1.39	1.56	1.71	1.99	1.55	1.80	2.00	2.19	2.54									
			SC	0.82	0.90	0.98	1.08	1.24	1.01	1.15	1.25	1.35	1.55	1.06	1.24	1.39	1.53	1.77	1.32	1.55	1.72	1.89	2.19									
	6	11	TC	0.92	1.04	1.14	1.23	1.42	1.07	1.25	1.38	1.51	1.75	1.20	1.40	1.55	1.70	1.97	1.58	1.85	2.06	2.25	2.59									
			SC	0.85	0.96	1.05	1.13	1.30	0.98	1.15	1.27	1.39	1.61	1.07	1.26	1.40	1.53	1.77	1.36	1.59	1.77	1.94	2.23									
	6	12	TC	0.79	0.93	0.99	1.06	1.19	0.99	1.11	1.20	1.29	1.47	1.13	1.28	1.39	1.51	1.73	1.42	1.66	1.85	2.03	2.35									
			SC	0.73	0.86	0.92	0.99	1.11	0.91	1.02	1.11	1.19	1.35	1.02	1.15	1.26	1.37	1.58	1.24	1.45	1.61	1.76	2.04									
7	12	TC	0.81	0.90	0.97	1.04	1.19	0.98	1.15	1.28	1.41	1.64	1.09	1.27	1.41	1.54	1.79	1.45	1.70	1.89	2.07	2.38										
		SC	0.75	0.84	0.90	0.97	1.10	0.90	1.05	1.18	1.30	1.51	0.99	1.15	1.28	1.40	1.63	1.27	1.49	1.66	1.82	2.10										
CWCH45	5	11	TC	1.45	1.62	1.81	1.94	2.21	1.69	1.90	2.12	2.27	2.59	1.90	2.13	2.37	2.54	2.94	2.41	2.71	3.09	3.38	4.10									
			SC	1.17	1.38	1.56	1.69	1.94	1.35	1.61	1.83	1.98	2.28	1.43	1.70	1.92	2.08	2.44	1.69	2.01	2.32	2.57	3.12									
	6	11	TC	1.37	1.55	1.74	1.86	2.12	1.61	1.83	2.05	2.21	2.60	1.83	2.05	2.31	2.52	3.03	2.37	2.74	3.18	3.53	4.35									
			SC	1.14	1.35	1.53	1.66	1.91	1.32	1.57	1.78	1.94	2.31	1.39	1.66	1.92	2.09	2.52	1.66	2.02	2.38	2.65	3.27									
	6	12	TC	1.29	1.45	1.63	1.74	1.98	1.53	1.73	1.93	2.07	2.36	1.73	1.93	2.16	2.31	2.64	2.22	2.48	2.81	3.06	3.68									
			SC	1.08	1.28	1.45	1.57	1.80	1.27	1.50	1.70	1.84	2.13	1.35	1.60	1.81	1.96	2.27	1.60	1.91	2.19	2.41	2.91									
7	12	TC	1.21	1.38	1.55	1.67	1.91	1.45	1.65	1.86	2.00	2.33	1.65	1.86	2.07	2.26	2.67	2.15	2.45	2.84	3.14	3.86										
		SC	1.05	1.25	1.41	1.52	1.76	1.23	1.47	1.67	1.80	2.12	1.31	1.56	1.78	1.94	2.33	1.57	1.92	2.24	2.48	3.05										
CWCH65	5	11	TC	1.91	2.14	2.42	2.56	2.96	2.21	2.50	2.82	2.99	3.47	2.50	2.82	3.19	3.37	3.94	3.15	3.56	4.09	4.40	5.42									
			SC	1.45	1.67	1.91	2.05	2.43	1.68	1.92	2.23	2.36	2.81	1.77	2.03	2.33	2.49	3.00	2.08	2.38	2.78	2.99	3.74									
	6	11	TC	1.80	2.02	2.30	2.43	2.82	2.10	2.37	2.70	2.85	3.40	2.39	2.69	3.06	3.28	3.99	3.03	3.49	4.12	4.47	5.64									
			SC	1.40	1.62	1.86	1.99	2.37	1.63	1.88	2.16	2.31	2.79	1.72	1.99	2.29	2.46	3.03	2.03	2.38	2.80	3.04	3.84									
	6	12	TC	1.69	1.91	2.15	2.27	2.64	2.00	2.26	2.55	2.70	3.13	2.28	2.56	2.90	3.05	3.54	2.91	3.29	3.75	4.00	4.92									
			SC	1.35	1.55	1.78	1.90	2.24	1.58	1.80	2.09	2.21	2.63	1.66	1.92	2.20	2.35	2.80	1.98	2.27	2.63	2.84	3.49									
7	12	TC	1.59	1.79	2.03	2.14	2.50	1.89	2.13	2.42	2.57	3.00	2.16	2.43	2.76	2.92	3.51	2.79	3.19	3.73	4.03	5.07										
		SC	1.30	1.50	1.72</																											

ELECTRICAL LOADS [230V 50Hz 1Ph (A)]

MODELS	25	45	65	75
ELECTRIC HEATER (1kW)	4.2	4.2	4.2	4.2
ELECTRIC HEATER (2kW)	8.3	8.3	8.3	8.3

AIRFLOWS

SPEED	1	2	3	4	5
	m ³ /s	m ³ /s	m ³ /s	m ³ /s	m ³ /s
CWC25	0.110	0.135	0.160	0.185	0.255
CWC45	0.105	0.130	0.155	0.180	0.240
CWC65	0.105	0.125	0.150	0.170	0.230
CWC75	0.125	0.155	0.175	0.205	0.240

CWCH25	0.110	0.135	0.160	0.185	0.255
CWCH45	0.105	0.130	0.155	0.180	0.240
CWCH65	0.105	0.125	0.150	0.170	0.230
CWCH75	0.125	0.155	0.175	0.205	0.240

CWC25T	0.140	0.170	0.190	0.220	0.270
CWC45T	0.140	0.170	0.180	0.220	0.270
CWC65T	0.135	0.160	0.180	0.210	0.260

CWCH25T	0.140	0.170	0.190	0.220	0.270
CWCH45T	0.140	0.170	0.180	0.220	0.270
CWCH65T	0.135	0.160	0.180	0.210	0.260

DISCHARGE VELOCITIES

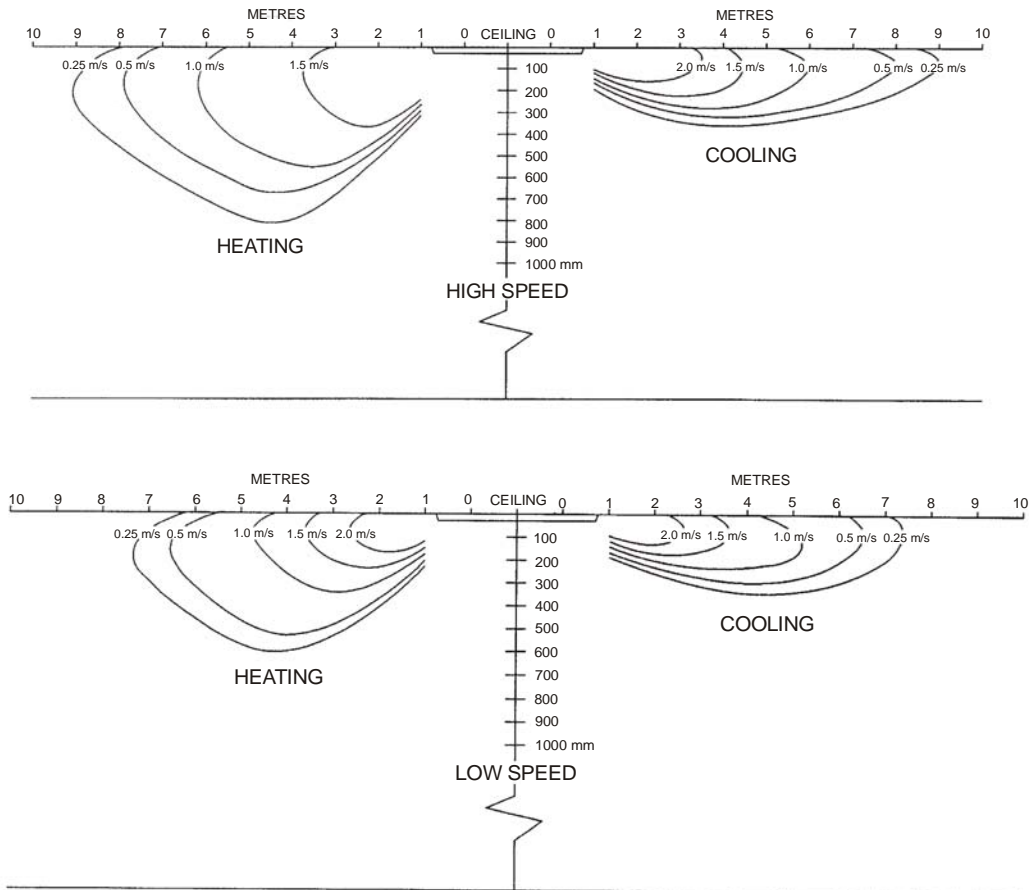

HYDRAULIC RESISTANCES

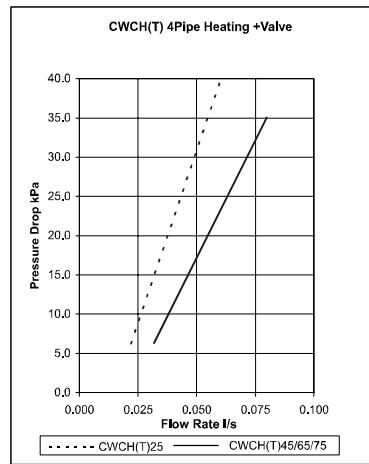
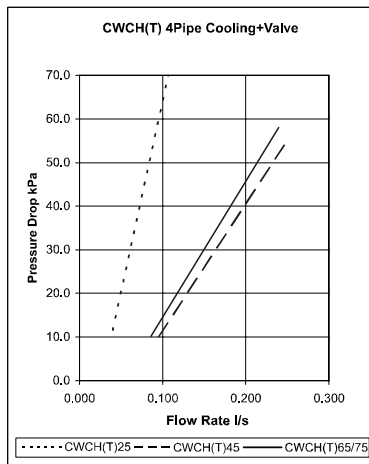
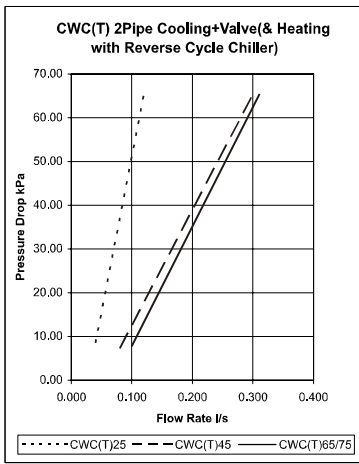
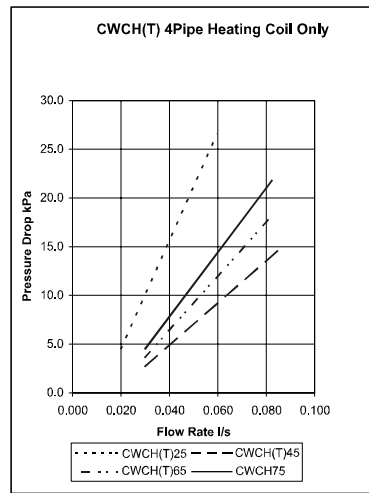
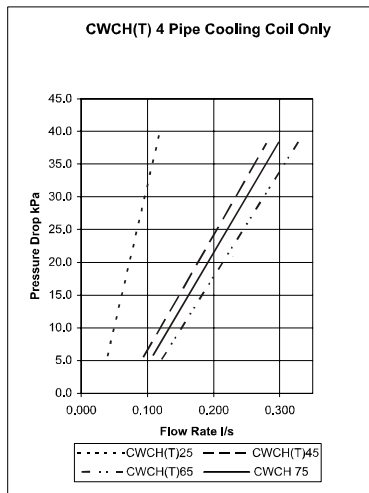
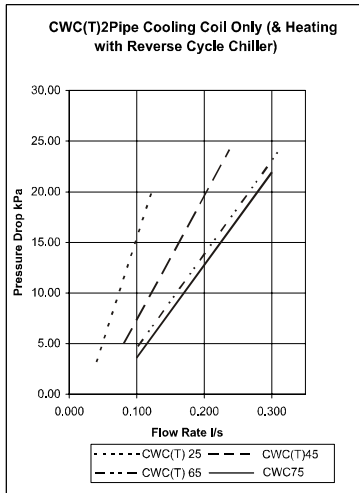

SOUND POWER and SOUND PRESSURE LEVELS

971 SERIES STANDARD CWC 600 (for speeds 1 = lowest, 5 = highest)

MODEL	SPEED	SOUND POWER LEVELS							SOUND PRESSURE LEVELS	
		Frequency Hz							dB(A)	NR
		125	250	500	1K	2K	4K	dB(A)		
25	1	39	41	38	28	22	14	37	33	28
	2	46	47	43	39	30	19	44	38	33
	3	50	51	47	45	35	25	49	44	39
	4	55	56	52	51	43	33	55	50	45
	5	62	64	59	58	54	45	62	57	52
45	1	39	40	38	26	21	13	37	30	25
	2	46	46	43	37	28	17	42	36	31
	3	50	50	47	43	35	23	48	40	35
	4	55	56	51	50	43	33	54	47	42
	5	63	64	59	58	55	45	62	55	50
65	1	40	38	37	24	21	13	36	27	22
	2	46	45	42	35	27	16	42	33	28
	3	50	49	46	42	34	22	47	37	32
	4	55	55	51	50	42	32	53	45	40
	5	62	63	59	57	53	44	61	52	47
75	1	46	43	40	31	24	15	40	30	25
	2	48	48	45	41	32	21	46	35	30
	3	53	53	49	48	39	29	51	42	37
	4	57	58	55	54	47	37	58	48	43
	5	63	65	60	59	54	45	62	53	48

971 SERIES TURBO CWCT 600 (for speeds 1 = lowest, 5 = highest)

MODEL	SPEED	SOUND POWER LEVELS						
		Frequency Hz						
		125	250	500	1K	2K	4K	dB(A)
25T	1	48	49	45	42	32	21	47
	2	53	54	49	49	39	28	52
	3	56	58	52	52	45	35	56
	4	61	62	57	56	51	42	60
	5	65	67	62	60	57	42	65
45T	1	47	48	45	41	32	20	47
	2	52	54	49	48	39	28	52
	3	55	57	52	52	45	35	55
	4	60	62	57	56	51	42	59
	5	64	67	62	60	57	46	65
65T	1	46	47	43	40	31	19	45
	2	51	53	48	47	38	28	51
	3	54	56	51	51	44	34	54
	4	59	61	56	55	50	41	59
	5	62	66	61	59	57	49	64

SOUND PRESSURE LEVELS	
dB(A)	NR
42	37
48	43
52	47
55	50
56	51
40	35
46	41
50	45
53	48
56	51
38	33
44	39
47	43
52	47
56	51

Sound Power Levels obtained in conformance with BS 4196: Part 5: 1981. Values are shown in dB with a standard reference of 1 pW.

The dB(A)/NR figures quoted are intended as a guide to the levels expected in a typical office environment at a distance of 1.4m.

Based on a cooling load of 120 W/m² with a chilled water flow of 6°C, return of 12°C, Room 23°C / 50%RH.

COIL WATER VOLUMES (Litres)

MODEL	25	45	65	75
CWC(T)(L) Chilled water coil	0.41	0.74	1.15	1.48
CWCH(T)(L) Chilled water circuit	0.32	0.56	0.97	1.21
CWCH(T)(L) LPHW circuit	0.09	0.18	0.18	0.27

BRANCH DUCT

The graphs below show the nominal amount of conditioned air passed by a single branch duct.

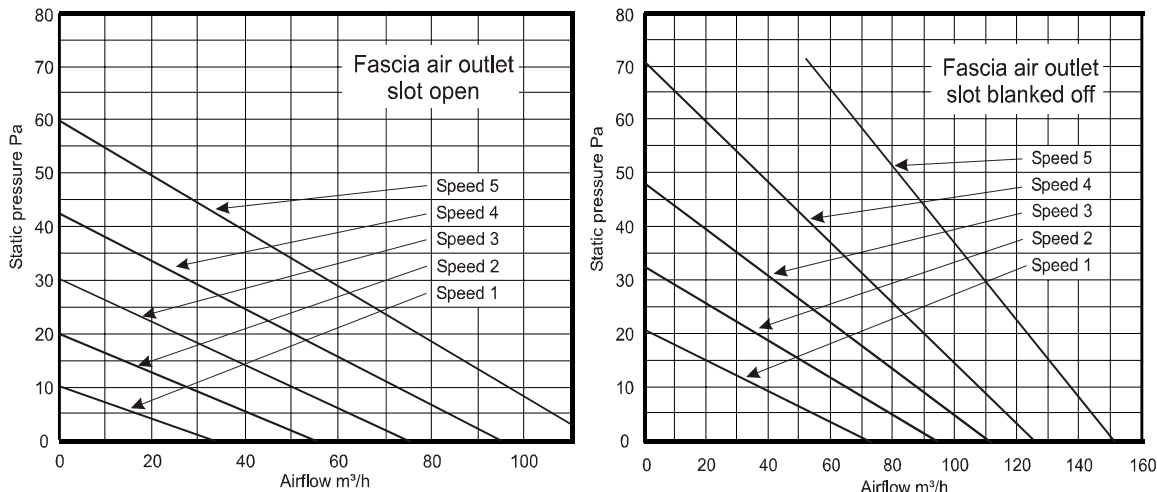

As shown on the graphs above, branch duct airflow can be increased by blanking off the fascia side to which the branch duct has been connected.

INSTALLATION

CONTENTS

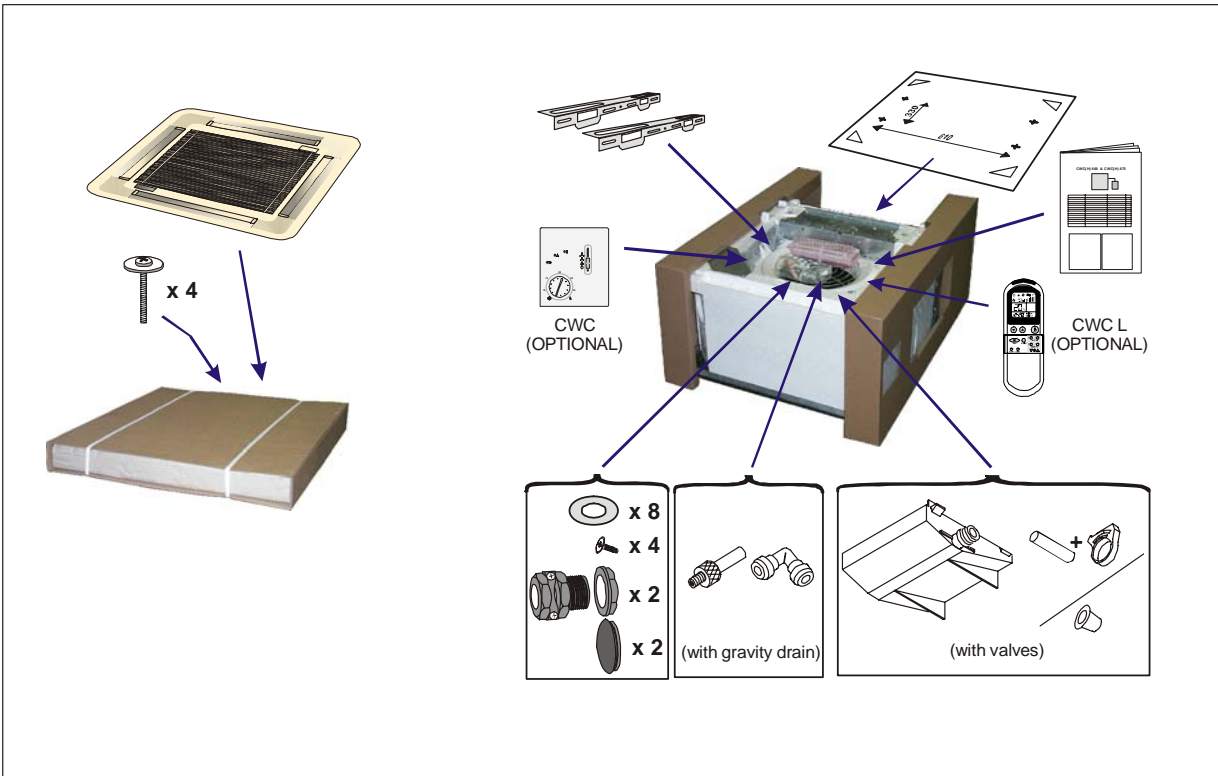

DIMENSIONS

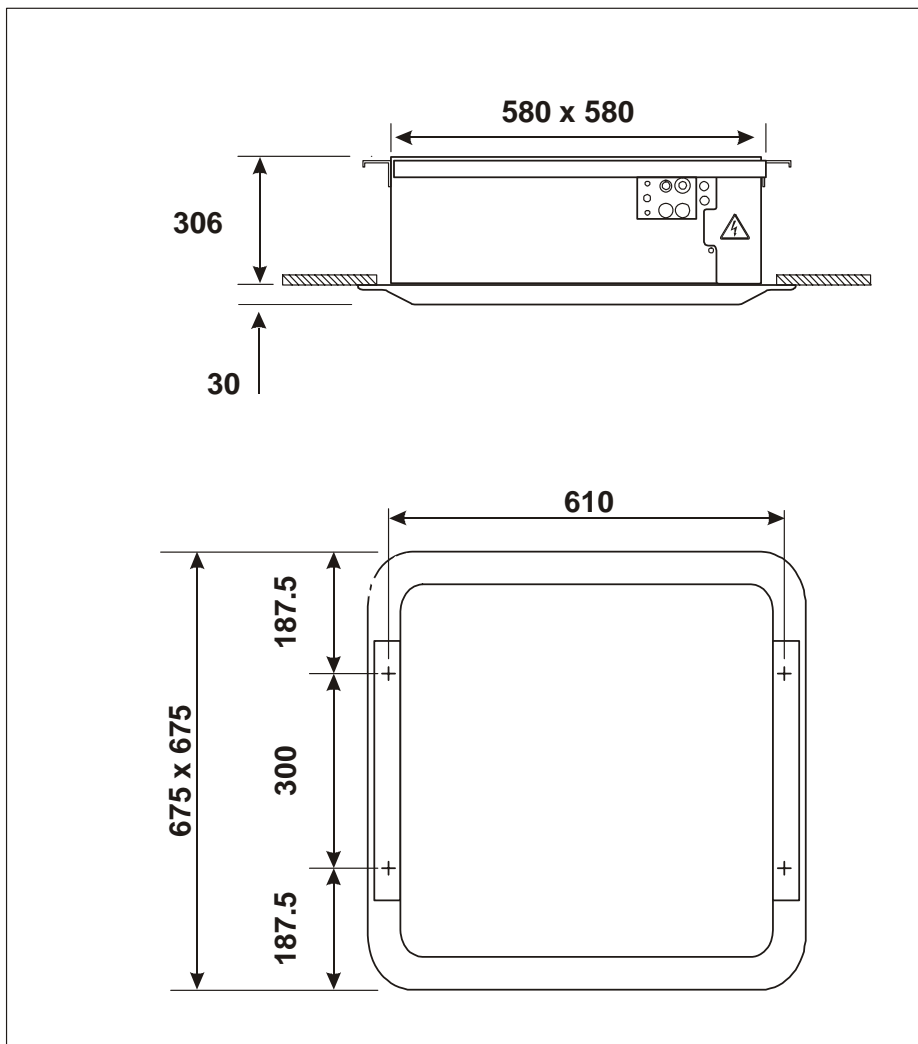

REMOVAL OF CHASSIS

CWC(T)(H)L

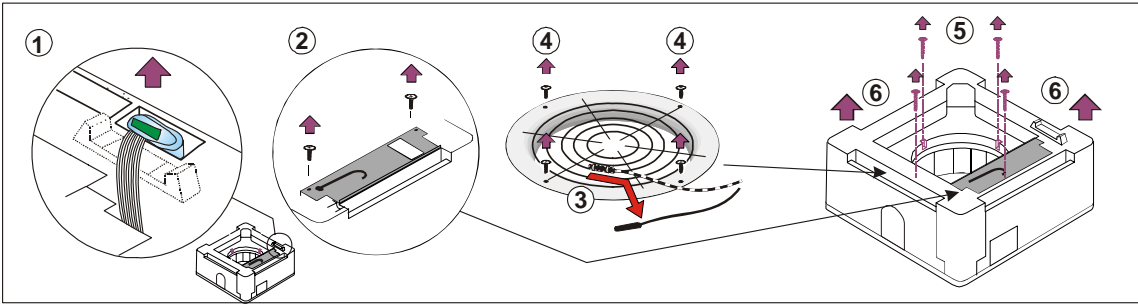

CWC(T)(H)

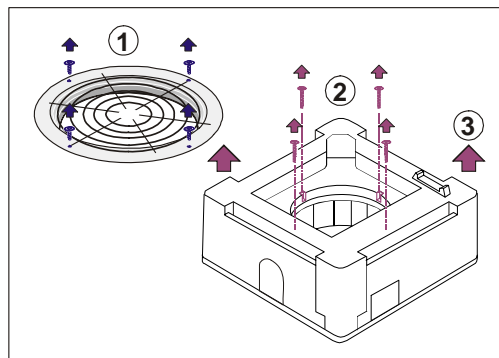

MOUNTING

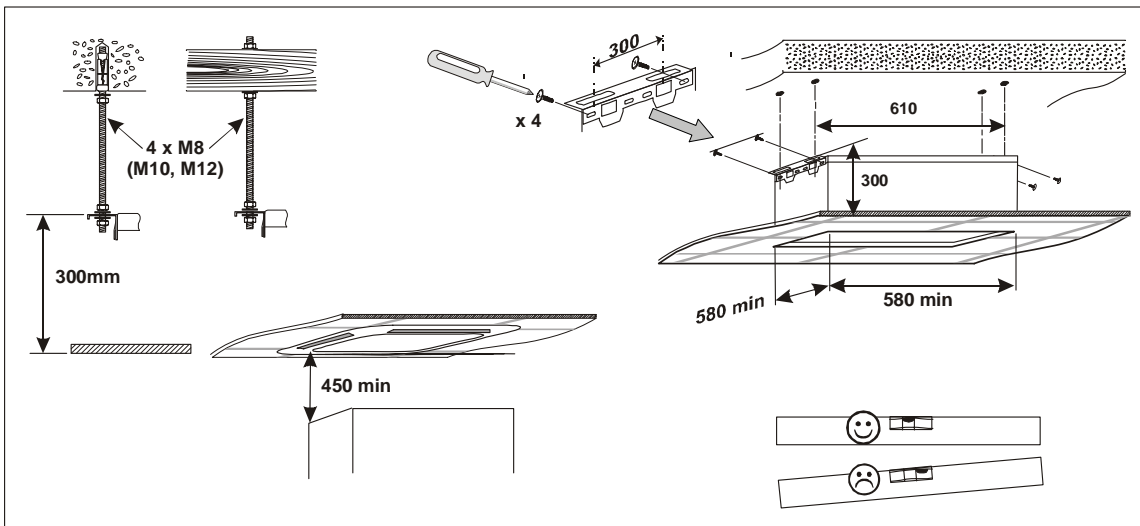

PIPEWORK

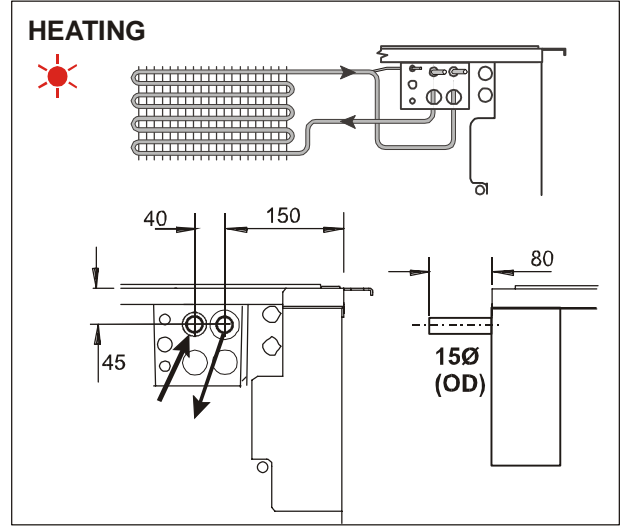
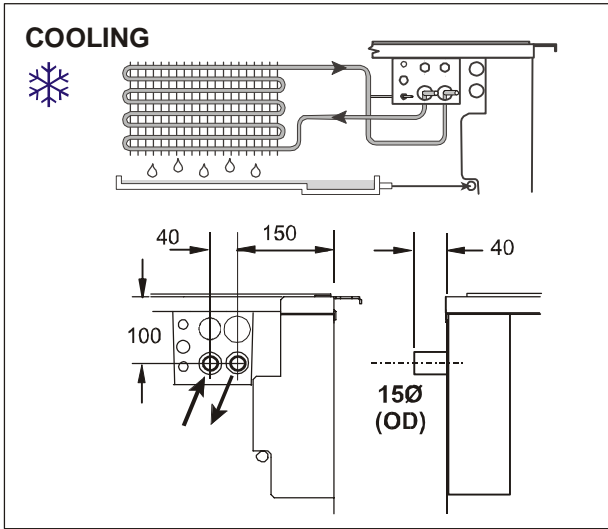

VALVE POSITION

	CWC(H)	FACTORY FIT	FIELD FIT OPTION
2 PORT			
4 PORT			

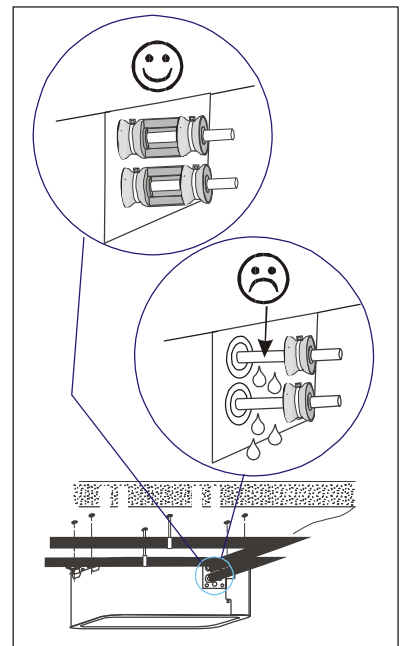

UNITS WITH VALVES

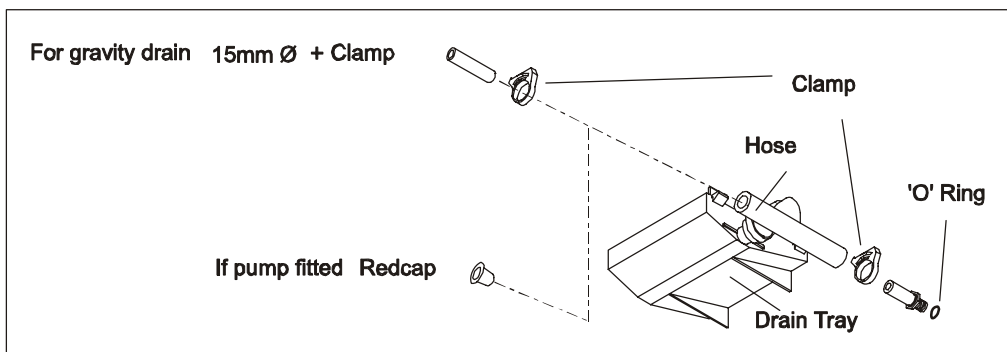

FUSES / DISJONCTEURS / SICHERUNGEN (EN60289) - MCBs (EN60898)

	No Electric Heater	Heater 1kW	Heater 2kW
Fuse (Amps)	5	10	10
kW@230V	---	0.96	1.92

INTERCONNECTING WIRING / INTERCONNEXIONS / VERBINDUNGSVERDRÄHTUNG

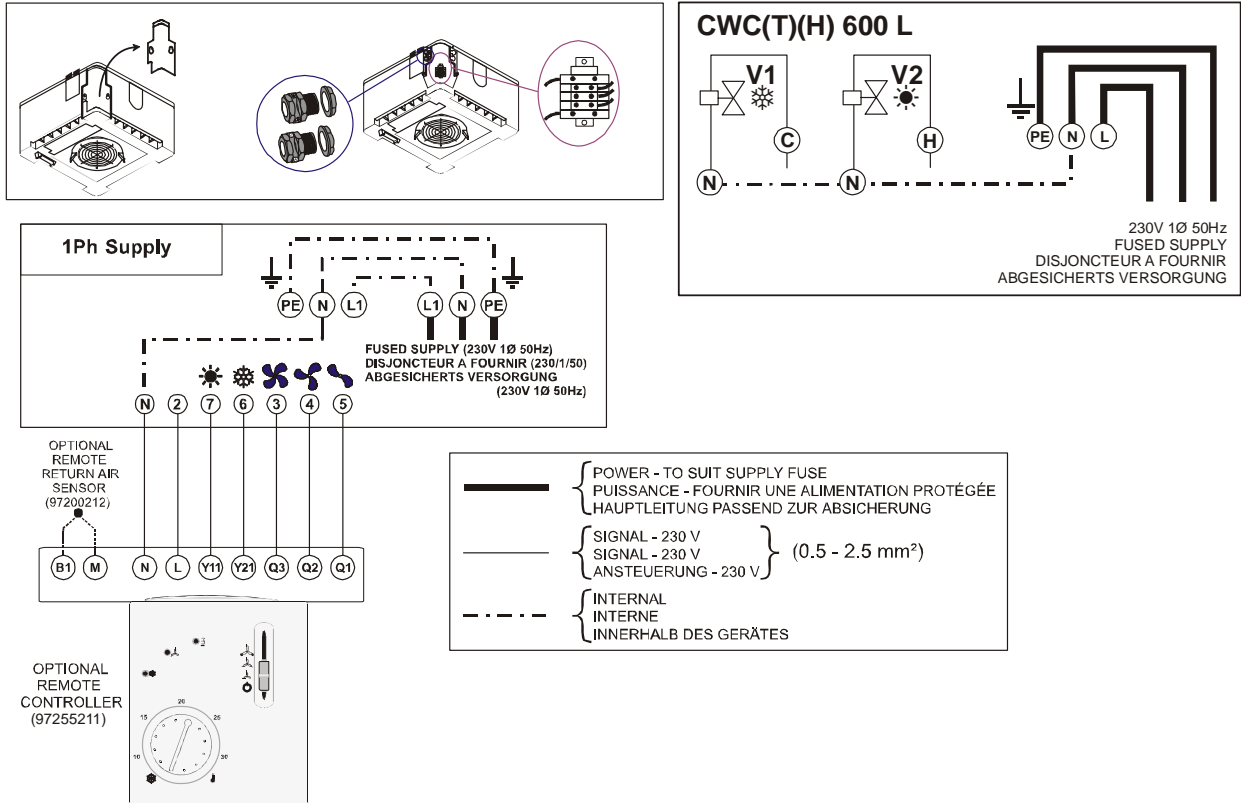

FAN SPEED SELECTION / SÉLECTION DES VITESSES DE VENTILATION / LÜFTERSTUFENAUSWAHL

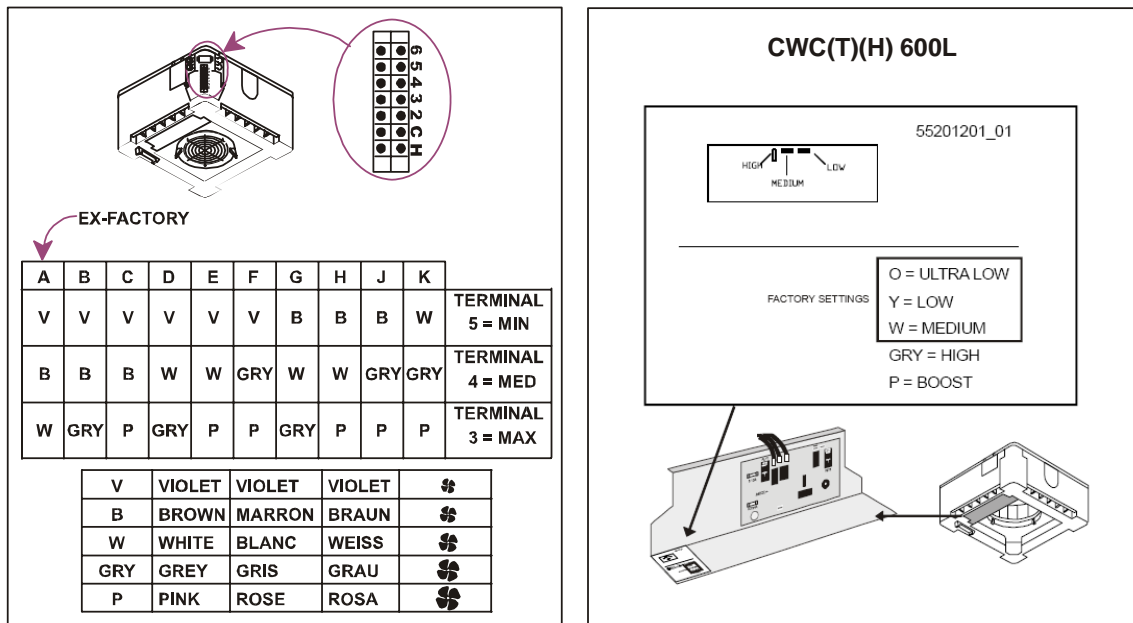

CONDENSATE DRAIN PIPING / EVACUATION CONDENSATS / KONDENSWASSERLEITUNG

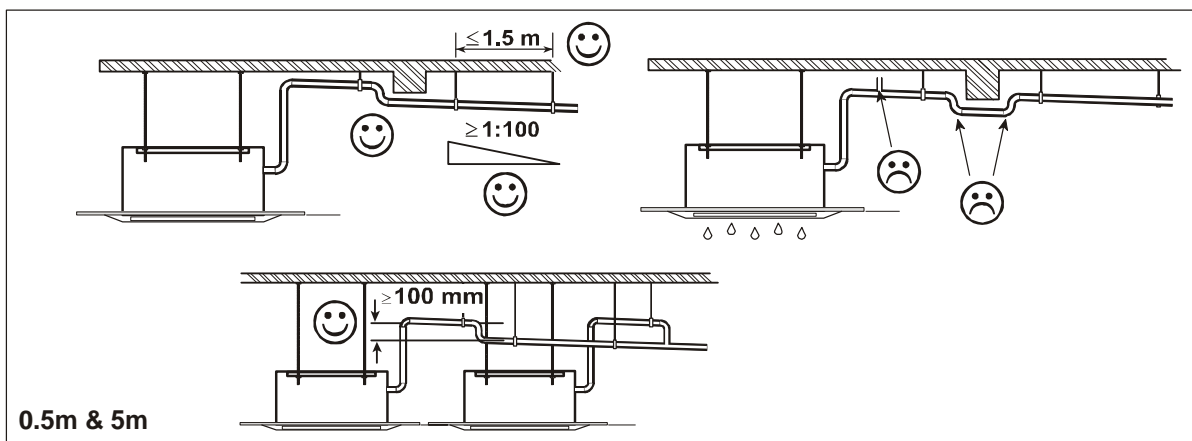
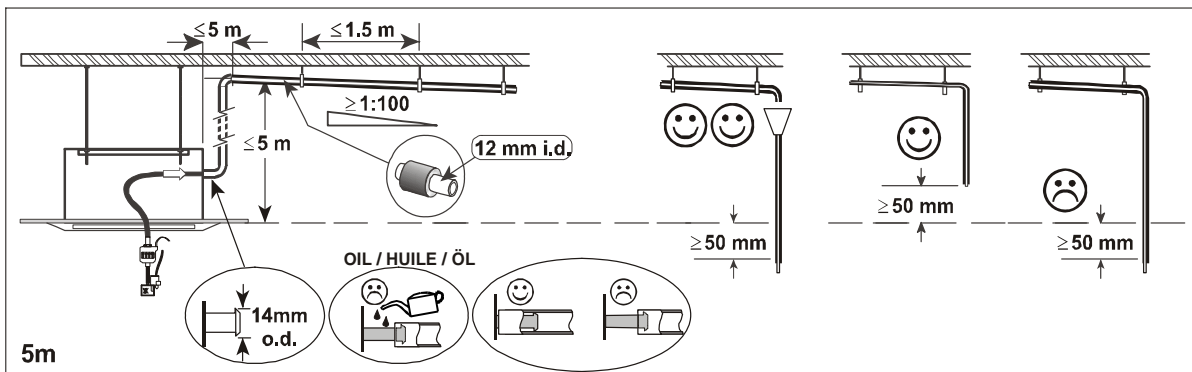
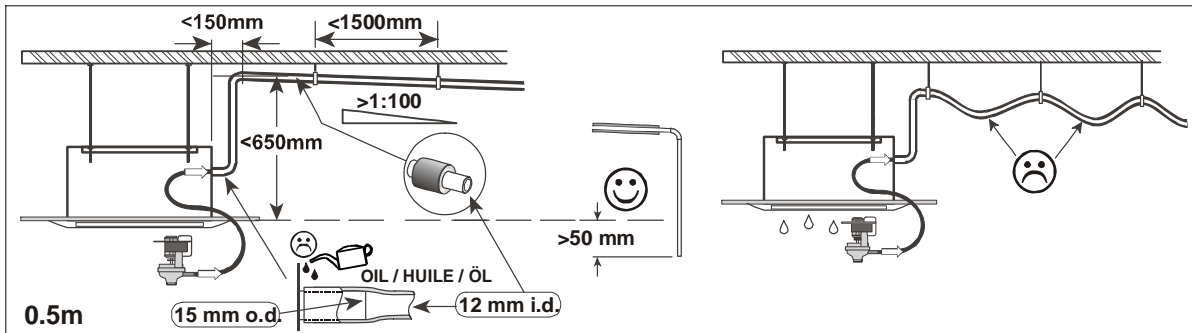
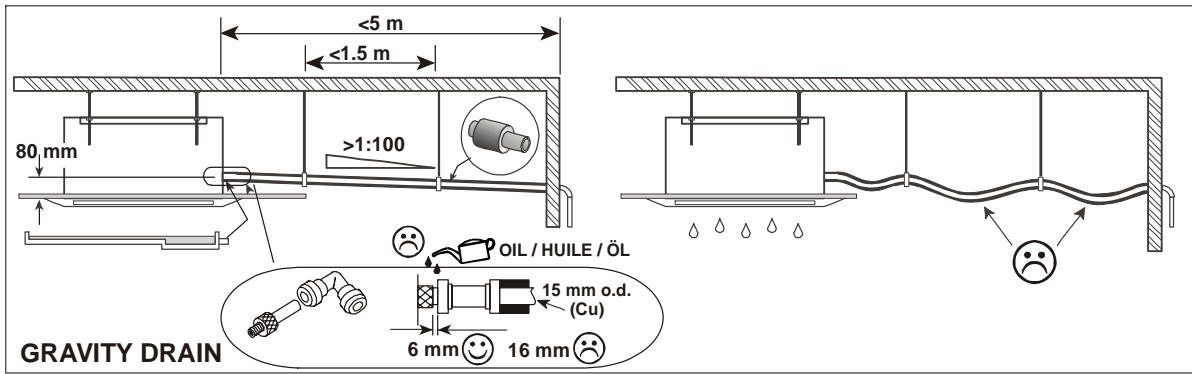

TESTING

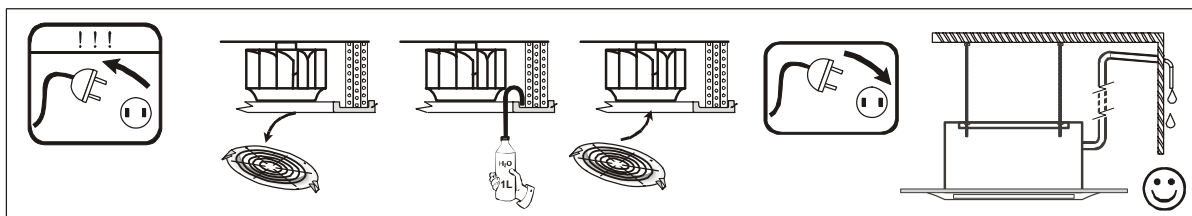

REINSTALLING THE CHASSIS CWC(T)(H)

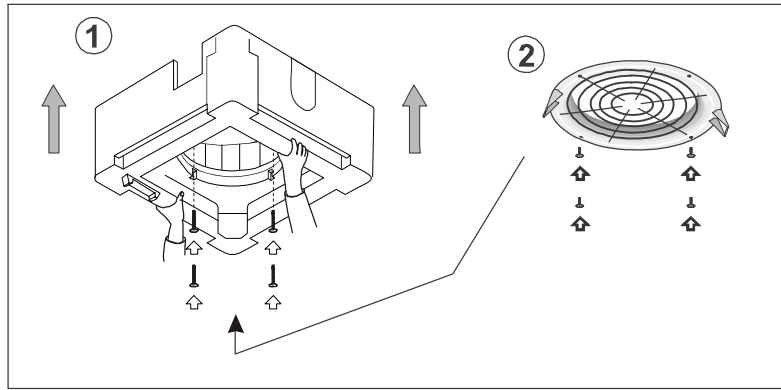

REINSTALLING THE CHASSIS CWC(T)(H) L

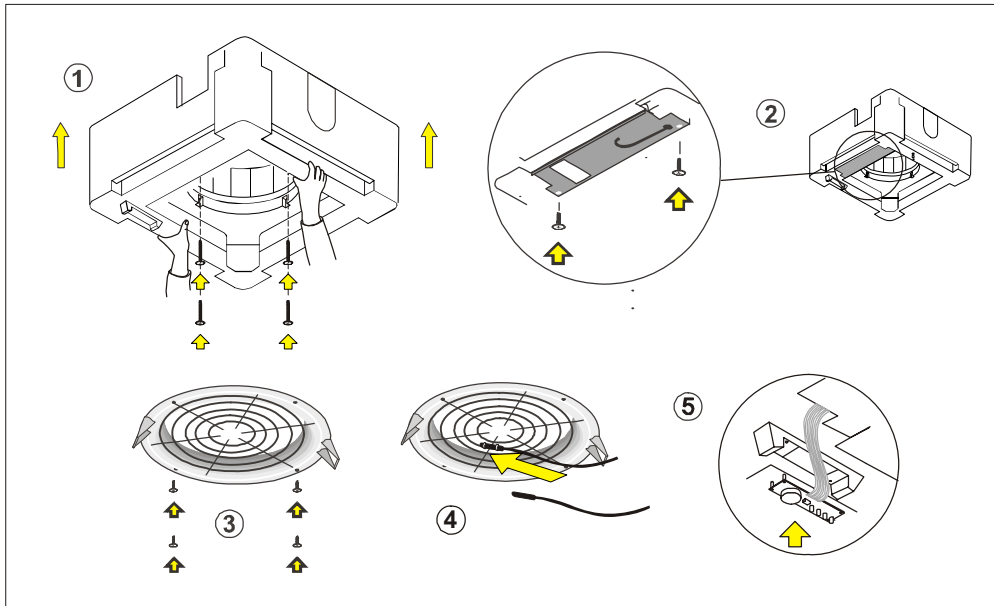

FITTING THE FASCIA

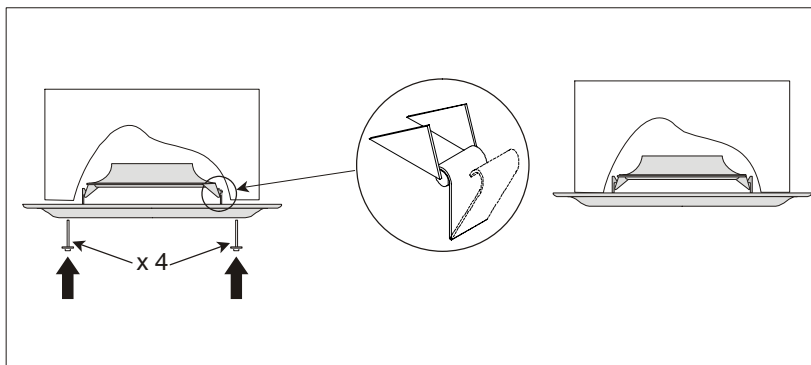

IR CONTROL CWC(T)(H) L

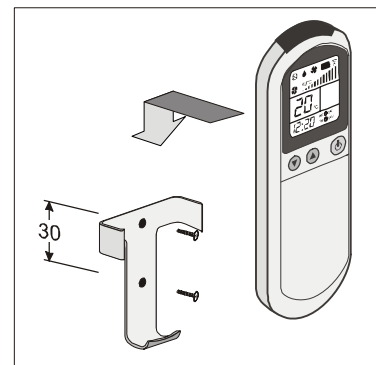

USER MAINTENANCE

ISOLATE THE UNIT ELECTRICALLY BEFORE COMMENCING ANY WORK

We recommend that in order to maintain maximum efficiency of this unit, it's important that the filter behind the return air grille is cleaned regularly.

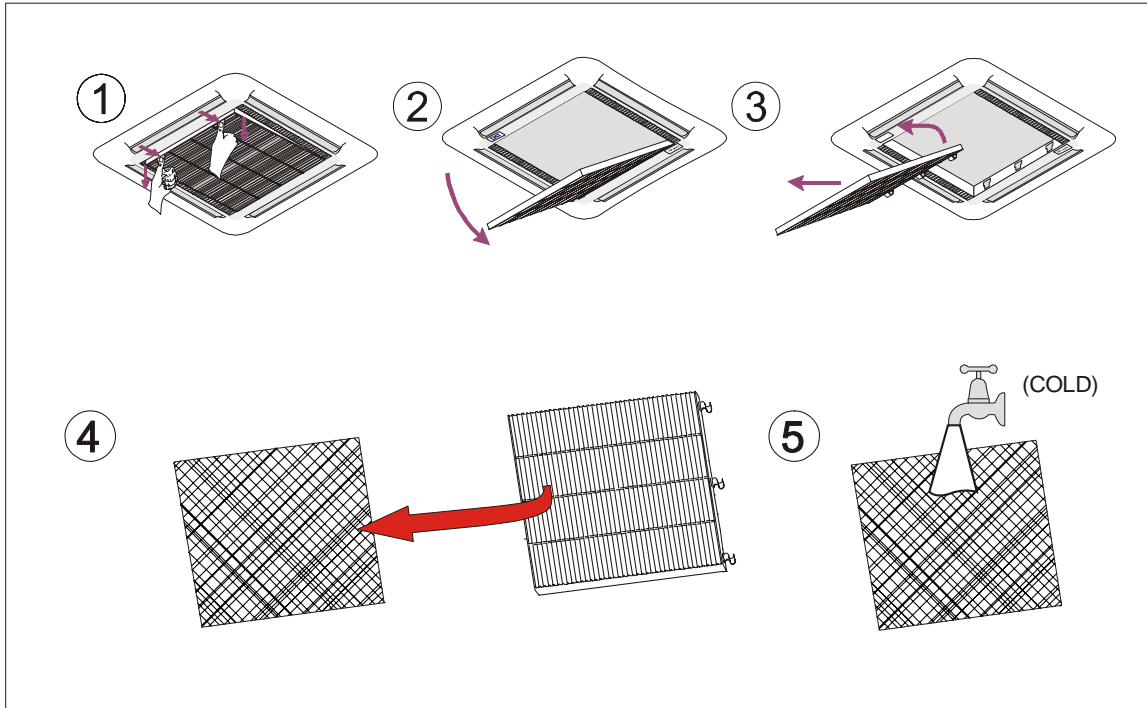

THE UNIT SHOULD ALWAYS BE USED WITH A FILTER. FAILURE TO DO SO WILL CAUSE A DECLINE IN UNIT PERFORMANCE AND MAY RESULT IN MALFUNCTION.

It is recommended that in order to prolong life and maintain performance of the unit, it is regularly serviced by a TEV installer / dealer.

FAULT FINDING

	CONDITION	POSSIBLE CAUSE	ACTION
A	Indoor fan motor will not run	No electric supply at socket or switched fuse box	Check fuse rating and replace if necessary. Check for loose electrical connections
		Unit wiring fault	Check wiring and connections
		Fan motor capacitor defective	Replace if faulty
		Fan motor defective	Replace if faulty
B	Inadequate cooling or heating	Dirty evaporator fins/filter	Clean if blocked
		Evaporator motor not running	As in section A
		Faulty thermostat or incorrectly set	Replace if faulty
C	System runs for long periods and will not cycle	Unit underrated for conditioned area	Check heat load against capacity
		Thermostat not operating correctly	Check wiring, position of phial and operation
D	Noisy unit	Worn motor bearing	Replace motor
		Casing or piping vibration	Check cause and rectify
		Loose parts or mounting	Find and tighten
		Bent fan blade	Replace fan
E	Water leaking from unit with a lift pump or condensate pump	Blocked drain or filter	Clear obstruction
		No supply to pump or loose connection	Secure the supply
		Pumping slowly	Check drain pipes; if clear, replace pump
		Pump windings shorted	Replace pump
		Fouled sensor (5m condensate pump only)	Clean sensor
F	Pump always runs	Faulty sensor or pcb	Replace sensor or pcb
G	No heating	Controls not set for heating	Reset
		Unit wiring fault	Check wiring and connections
		Dirty evaporator fins/filter	Clean
		Faulty thermostat	Check for signal; replace if faulty
		Faulty heater element	Replace
		Faulty heater cutout	Replace, (check for short circuiting)
		No heaters/LPHW coil fitted	Fit electric heater or LPHW
		Heating valve not operating	Check wiring, actuator

CWC(T)(H) L LED DISPLAYS

Cool ❄️ Green	Dry 💧 Red	Fan ⚙️ Red	Heat 🔥 Amber	
OFF	OFF	OFF	OFF	No power, manual OFF, timed OFF, condensate high level, fault in condensate control
ON	OFF	OFF	OFF	Cooling mode selected
ON	OFF	OFF	BLINKS	AUTO - predominantly cooling
OFF	OFF	OFF	ON	Heating mode selected
BLINKS	OFF	OFF	ON	AUTO - predominantly heating
OFF	OFF	ON	OFF	Fan mode selected
OFF	ON	OFF	OFF	Dry mode selected (unit removes moisture by cycling cooling at low speed, humidity is reduced, but room temperature is not changed)

Diagnostics

OFF	OFF	BLINKS x 4	OFF	Room sensor missing
OFF	OFF	BLINKS x 4	OFF	Indoor coil sensor missing

EXPLODED VIEW

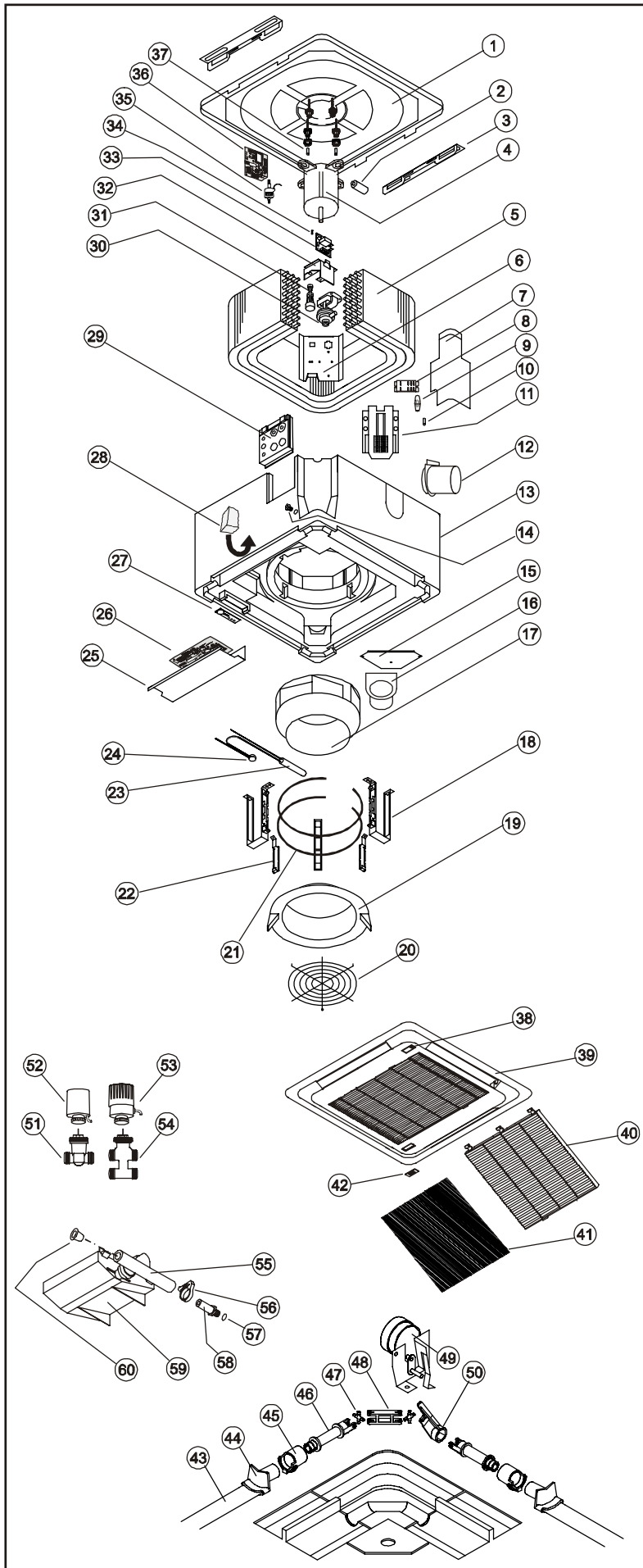

1	Top panel
2	Capacitor
3	Suspension bracket
4	Fan motor
5	Heat exchanger
6	Coil blanking panel
7	Electric box cover
8	Heater relay
9	Fuseholder
10	Unit fuse
11	External electrics box
12	Branch duct kit
13	Chassis
14	Threaded drain plug
15	Fresh air corner plate
16	Fresh air duct
17	Fan
18	Coil bracket
19	Fan cowl
20	Fan guard
21	Heater element
22	Heater retaining bracket
23	Thermal fuse
24	Heater cut-out
25	Internal electrics cover
26	CWC(T)(H) L main PCB
27	CWC(T)(H) L receiver PCB
28	Blanking foam
29	Pipe panel
30	Lift pump (0.5m)
31	Float switch (0.5m)
32	PCB bracket
33	PCB, lift pump
34	Pump fuse (315mA),
35	Condensate pump (5m)
36	PCB, condensate pump
37	Motor mounts
38	Blank (LED cover, CWC L)
39	Fascia
40	Grille
41	Filter
42	Badge
43	Air deflector vane
44	Vane end cap
45	Vane bearing
46	Vane connector
47	Spider
48	Double yoke
49	Vane motor
50	Actuator arm
51	2 port valve
52	2 port actuator
53	4 port actuator
54	4 port valve
55	Drain hose
56	Hose clamp
57	O-ring
58	Drain connector
59	Valve drain tray
60	Redcap